

Ai429XCV - TRANSCIVER CLASS

■ TRANSMITTER ■ RECEIVER ■ TESTER ■ ANALYZER ■ MONITOR ■

APPLICATIONS

- ✓ Aircraft System Simulation (SIM)
- ✓ Automated Test System (ATS)
- ✓ Ground Support Equipment (GSE)
- ✓ Validation & Verification (V&V)
- ✓ Regression Testing (RT)
- ✓ Extended Stress Testing (ESS)
- ✓ System Diagnostic
- ✓ Software Development
- ✓ Flight Line Diagnostic
- ✓ Portable Tester
- ✓ New Product Development (R&D)

RECEIVER

429 Receives up to 16/sixteen simultaneous 429 inputs, the Ai429 can filter received data based on speed and parity. Each channel's input pin pair can be swapped, and speed automatically detected. Once a 429 word is received, it can be routed to the host computer. The host can request for the system to filter which port, labels and SDIs to show/hide, as well as decode and format the received data to be visually interpreted by the user.

TRANSMITTER

429 Transmits up to 16/sixteen simultaneous 429 outputs. Each output is completely independent from the others and can be set to various speeds, throughput cap, output pin connection swap, parity settings and error injections.

GENERIC Ai429XCV-ES SERIAL MODEL SETUP

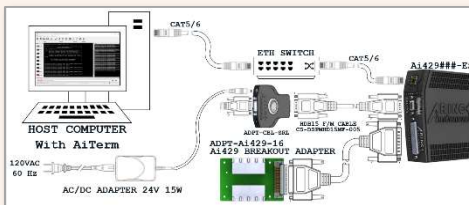

GENERAL Ai429XCV-EU USB MODEL SETUP

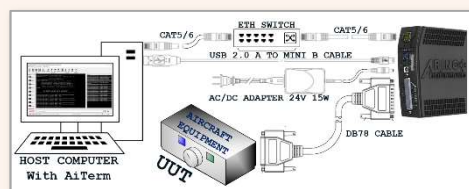

GENERAL MOUNTING OPTIONS

The device can be mounted in several different ways. It can be *table/desk* mounted by installing the rubber feet. It can be *DIN rail* mounted or *rack* mounted. The width is such that three devices can fit on a standard commercial 19-inch shelf and will take no more than one U in height.

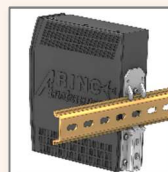

FEATURE LIST

- ✓ Tabletop, DIN rail, panel and 1U of 19" rack mountable (3 across 19" shelf)
- ✓ Lightweight: less than 1 lbs.
- ✓ Low power: less than 4 Watts
- ✓ Up to 16/Rx & 16/Tx simultaneous ARINC 429 channels
- ✓ Maximum throughput on all channels
- ✓ Independent programmable bit rate on all transmit & receive channels
- ✓ Bridges/converts ARINC 429 bus with RS-232, RS-422, USB or Gig Ethernet
- ✓ Platform independent – no drivers
- ✓ Command line interface (CLI) console
- ✓ Compatible with terminal software such as PUTTY, TeraTerm and similar
- ✓ Human readable data stream
- ✓ Programmable time tag range, format and accuracy
- ✓ Programmable AutoResponder for special protocol (such as ACARS)
- ✓ Programmable Security Level Access
- ✓ Cross-platform standard script access
- ✓ Cross-platform open source C/C++ software API library (**Ai429API**)
- ✓ Free GUI Terminal Application (**AiTerm**)

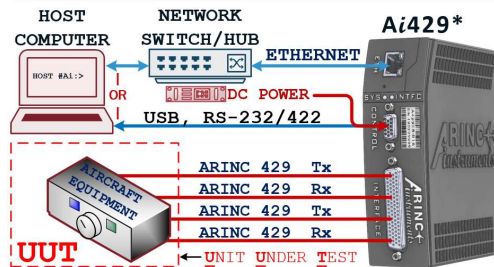

HARDWARE

The Ai429 is a cross-platform ARINC 429 bus interface, test and management device. It allows the user to interface, transmit & receive ARINC 429 data via any host computer. The host connection can be either Ethernet for speed or serial (USB or RS-232/RS-422) for convenience. Available in 4, 8, 12 and 16 transmit and receive channel pairs, the Ai429 products offer complete and unsurpassed features not found in any other competing products.

There are three classes of Ai429 device: transceiver/XCV, tester/TST and mixer/MXR. The transceiver class (denoted by the Ai429XCV) allows the user to monitor, transmit & receiver multiple ARINC 429 data buses via cross-platform host interface (Ethernet/serial) using a free GUI, command line interface, scripts or a software API library.

The tester class (denoted by the Ai429TST) provides all the features of the transceiver class with the added functionality of testing the buses by auto-generating user specified test patterns and injecting errors on command.

The mixer class (denoted by the Ai429MXR) provides all the features of the transceiver and tester products with the added functionality of: mixing, routing, filtering, merging & splitting ARINC 429 buses similar to a managed Ethernet switch.

FREE AiTerm GUI TERMINAL APPLICATION

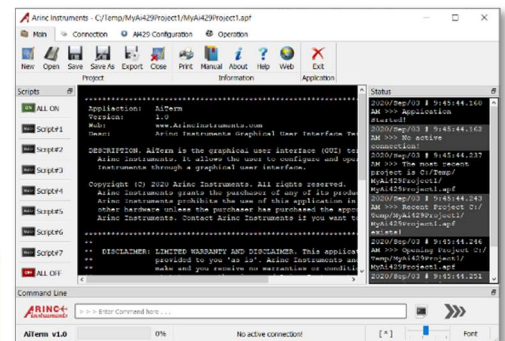

SPECIFICATIONS

ARINC 429 Receive Channels

- **Number of channels:** 4, 8, 12 up to 16
- **Standard Data Rates:** 12.5k, 100k & auto detect
- **Non-Standard Data Rates:** 50 bps to 115 kbps auto detected
- **Standard input levels:** ±6.5 to ±13 VDC (A to B)
- **Parity:** odd, even or none
- **Error Detection:** Parity and Data Rate.

ARINC 429 Transmit Channels

- **Number of channels:** 4, 8, 12 up to 16
- **Standard Data rates:** 12.5k and 100k
- **Non-Standard Data Rates:** 50 bps to 115 kbps programmable.
- **Standard output levels:** ±11vdc (A to B)
- **Parity:** odd, even or none
- **Slew Rate:** Automatic slew rate adjustment
- **Error injection:** Parity, Pin Swap, Bit Count, Word Gap, Data Rate, Duty Cycle & Slew Rate

Serial Model's Control Port

- **Control Port is DB15HD & can change bus type**
- **Bus:** EIA/RS-232
 - **Data rate:** 50 bauds to 1M baud
 - **Flow control:** software, hardware or none
- **Bus:** EIA/RS-422 full duplex
 - **Data rate:** 50 to 1M bauds
 - **Flow control:** software or none
- **Configuration Strap:** four pins are used as configuration straps to choose between modes and PC connectivity.

USB Model's Control Port

- **Bus:** USB 2.0 (micro USB connector)
- **Power:** 2x5.5 mm power barrel jack connector
- **Configuration Strap:** Hex Rotary Switch

Ethernet Port

- **Bus:** 10/100/1000b-T Ethernet full duplex
- **Protocol:** Raw, TCP/IP Client/Server, with support for DHCP

Status Indicators

- Tri-color System Status LED
- Tri-color Interface Status LED

Software / Firmware Interface

- Standard Command Line Interface (CLI)
- Open Source Graphical User Interface (GUI)
- Open Source High-level Software Application Programming Interface (API)
- Script Interface

Mechanical

- **Dimension:** 5.8" x 1.7" x 5.4"
- **Weight:** 1 lbs. max
- **Mounting option:**
 - Optimal table mount removable Rubber Feet
 - Standard DIN rail adapter
 - Standard 19" 1U rack mount (3 across shelf)
 - Standard Panel Mount

Environmental

- **Storage:** -40°C to +85°C
- **Operating:** 0°C to +70°C

Power

- **Voltage:** +10 to +36 VDC
- **Power:** 4 Watts max.

Ordering Information

Part Number	Description
Ai429XCV-ES04	4Tx/4Rx channels ARINC 429 transceiver class, RS-232/422 serial model, Gig Ethernet
Ai429XCV-EU04	4Tx/4Rx channels ARINC 429 transceiver class, USB serial model, Gig Ethernet
Ai429XCV-ES08	8Tx/8Rx channels ARINC 429 transceiver class, RS-232/422 serial model, Gig Ethernet
Ai429XCV-EU08	8Tx/8Rx channels ARINC 429 transceiver class, USB serial model, Gig Ethernet
Ai429XCV-ES12	12Tx/12Rx channels ARINC 429 transceiver class, RS-232/422 serial model, Gig Eth.
Ai429XCV-EU12	12Tx/12Rx channels ARINC 429 transceiver class, USB serial model, Gig Ethernet
AiTerm-Win	(Free) Arinc Instruments Terminal Application for Windows platform
AiTerm-Lnx	(Free) Arinc Instruments Terminal Application for Linux platform
AiTerm-Mac	(Free) Arinc Instruments Terminal Application for Mac OS platform
Ai429API	(Free) Cross-platform open source Application Programming Interface C/C++.
ADP-CBL-SRL	Control Port Cable Adapter for Serial Models (RS-232/422, power & configuration)
ADP-INTFC-Ai429-16	Ai429 16 Ports Interface Breakout Adapter



SERIAL MODEL



USB MODEL

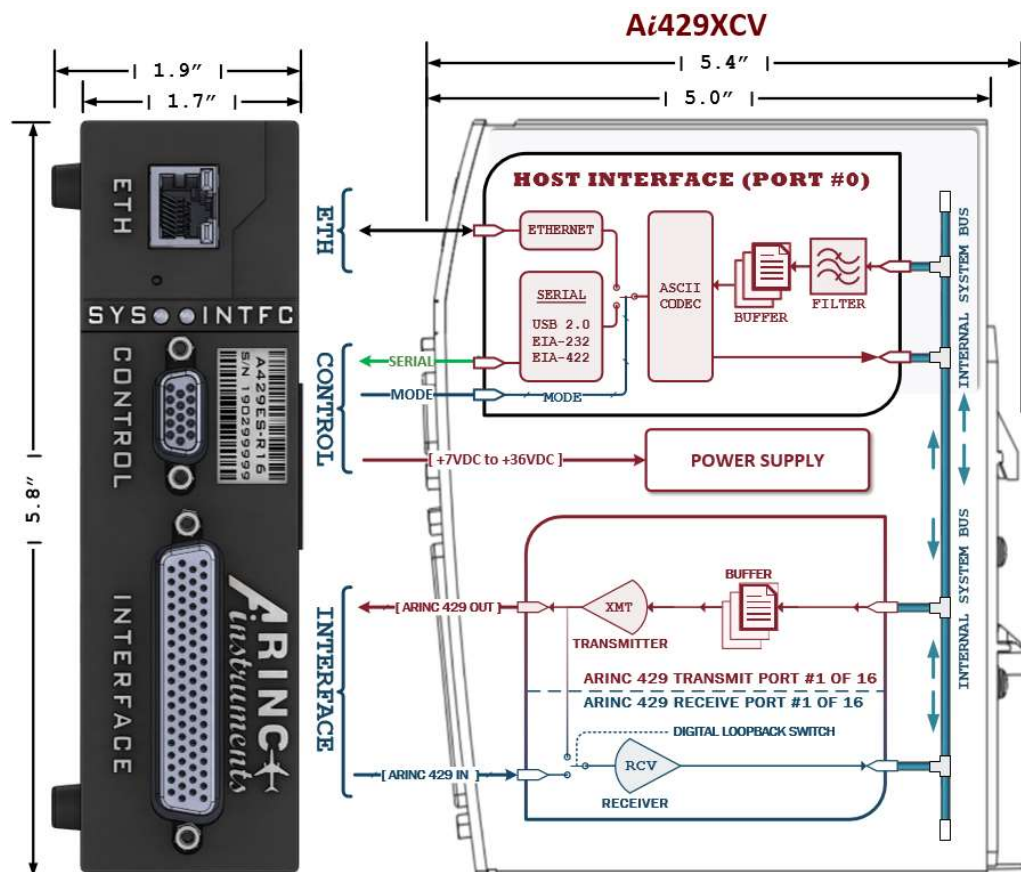

ARINC
Instruments

SPARK OF INGENUITY

P.O. BOX 5677, Sun City Florida, 33571

www.Arinclnstruments.com

Locate a Sales Representative visit: www.Arinclnstruments.com/sales

© Copyright 2021 ARINC Instruments. All Rights Reserved.

All other brands, names or trademarks are property of their respective owners.

Specifications are subject to change without notice.